

PUMP DISASSEMBLY

Refer to Figure 2.

1. Lay the pump assembly on a workbench.
2. Remove the three (E) nuts from the three (F) spacer rods.
3. Pull the air motor from the lower pump end until air motor piston rod is on "down" position and lower pump end rod is in "up" position.
4. Slide (A) retaining ring upward.
NOTE: A snap ring tool is recommended for proper handling of retaining ring.
5. Slide (B) sleeve towards air motor on the air motor piston rod.
6. Remove two (C) connectors and lay air motor aside.
7. Repeat steps, 4, 5, and 6 to remove other connector. Then remove (D) extension rod.
8. Unscrew three (F) spacer rods only if disassembly of lower pump end is necessary.

PUMP ASSEMBLY

Note: All threads are right hand.

1. Align Lower End Pump Rod with (D) extension rod and Air Motor Piston rod. Position air inlet of motor 65° from material outlet.
2. Position two (C) connectors in place and slide (B) sleeve over two (C) connectors.
3. Slide (A) retaining ring into groove.
NOTE: Repeat step 2 to secure other connector to (D) extension rod.
4. If three (F) spacer rods were removed in step 8 of disassembly of air motor from lower pump end, screw spacer rods into lower pump end.
5. Push air motor and lower pump end together so spacer rods slide thru holes located in air motor base.
6. Secure air motor to lower pump end using three (E) nuts.

TROUBLE SHOOTING

• PROBLEM

___Cause, solution.

• Pump will not cycle.

- ___No pressure to motor, See motor manual.
- ___Restricted return lines, clean obstruction.
- ___Damaged motor, service motor.

___Be sure to eliminate any possible non-pump problems before suspecting pump malfunction and continuing.

• Pump problems will typically occur in one of two areas:

1. The Air Motor Section.
2. The Lower Pump Section.

___Determine which section is affected.

SPACER SECTION

| REF | PART NO. | DESCRIPTION |
|-----|--------------|----------------|
| A | 91547 (2) | RETAINING RING |
| B | 91546 (2) | SLEEVE |
| C | 91644 (4) | CONNECTOR |
| D | 92815-2 | EXTENSION ROD |
| E | Y85-29-C (3) | HEX HEAD NUT |
| F | 92817 (3) | SPACER ROD |

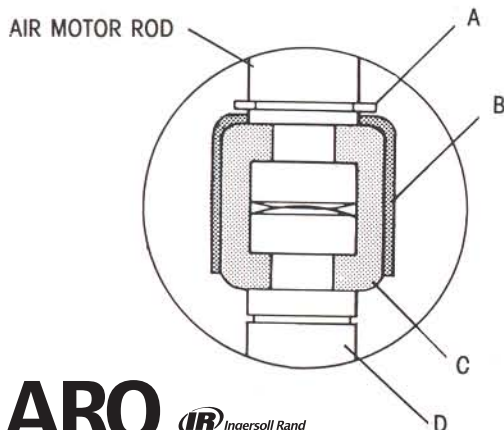

FIGURE 2

